



KEY-DISP

Electric Bicycle Meter
User's Guide

KD21C

contents

Product name and model.....	1
Appearance and Size.....	1
◆Materials and Color.....	1
Function Summary and Button Definition.....	2
◆Function Summary.....	2
◆Functional Area Distribution.....	2
◆Button Definition.....	2
General Operation.....	2
◆Power On/Off.....	2
◆Turn on/off Backlight.....	3
◆PAS Level Selection.....	3
◆Battery Indicator.....	4
Error Code Information.....	4
General Setting.....	4
◆Trip Distance Clearance.....	5
◆Backlight Contrast setting.....	5
◆ Inch and Metric Conversion.....	5
General Parameter Setting.....	5
◆Wheel Diameter Setting.....	6
◆Speed-limit Setting.....	6
Personalized Parameter Setting.....	6
◆Battery Power Bar Setting.....	7
◆Power Assistant Level Setting.....	7
Power Assistant Level Select.....	7
PAS Ratio setting.....	7
◆Controller Over-Current Cut Setting.....	8
◆Power Assistant Sensor Setting.....	8
The Direction of Power Assistant Sensor Setting.....	8

The Sensitivity of PAS Setting.....	8
Magnet quantity Setting.....	9
◆Speed Sensor Selection.....	9
◆Throttle Definition.....	9
Throttle Assistance Push Enable/Disable.....	9
Throttle Level Enable/Disable.....	10
◆System Setting.....	10
Delay time setting of battery power.....	10
Max speed limited.....	10
Button PAS Setting.....	11
PAS Speed Setting.....	11
Slowly Start up Setting.....	11
◆Power-on Password Setting.....	12
Power-on Password Enable.....	12
Power-on Password Modify.....	12
◆Exit setting.....	13
Recover default setting.....	13
Operation Cautions.....	13
Quality assurance and warranty scope.....	13
I 、 Warranty.....	13
II 、 Other items.....	14
Connection layout.....	14

Product name and model

Electric bicycle intelligent LCD instrument; model: KD21C.

Specifications

- 24V/36V/48V Power Supply
- Rated current 10mA
- The maximum working current 30mA
- Off leakage current <1uA
- The supply controller working current 50mA
- The use temperature -20°C~ 60°C
- Storage temperature -30°C~ 70°C

Appearance and Size

◆Materials and Color

KD21C product's shell and hook are made of ABS and Nylon respectively. LCD transparent window lens is high hardness acrylic. Between -20°C and 60°C temperature, the mechanical performances of the shell materials are excellent, which ensure the usability of the shell.

Display appearance and dimension figure (unit: mm)

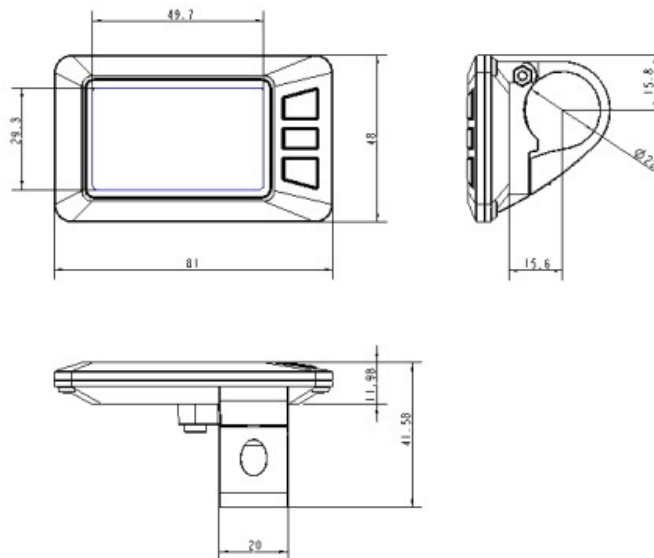

Function Summary and Button Definition

◆Function Summary

KD21C can provide a lot of functions to fit the users' need. The indicating contents are as following.

- Battery Indicator
- Power assist level adjustment Indicator
- Speed Display
- Trip distance and total distance
- 6km/h Cruise control
- Headlight On/Off
- Error Code Indicator
- Various Parameters Setting (like wheel size, speed-limited, battery level bar, PAS level, controller limited current, max speed, password enable, and so on.)
- Recover Default Setting

◆Functional Area Distribution

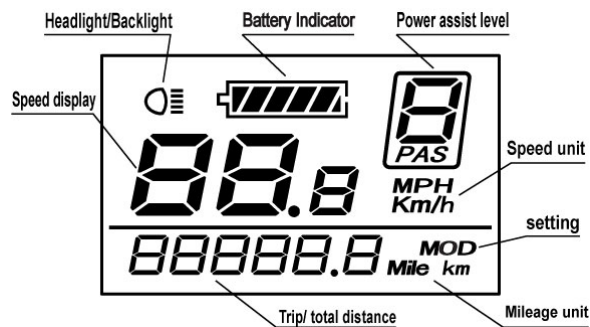

Functional area distribution

◆Button Definition

There are three buttons(MODE, UP and DOWN) on the KD21C display, such as



General Operation

◆Power On/Off

Hold **MODE** button then the display will power on. In like manner hold **MODE** to turn off power when the display working. When the display off the leakage current is less than 1 uA.

- When parking e-bike for more than 10 minutes, the display shut down automatically.

◆ Mileage Interface

After starting up the display, default is total distance. Press **MODE** to shift the indicating information between single trip distance and total distance.

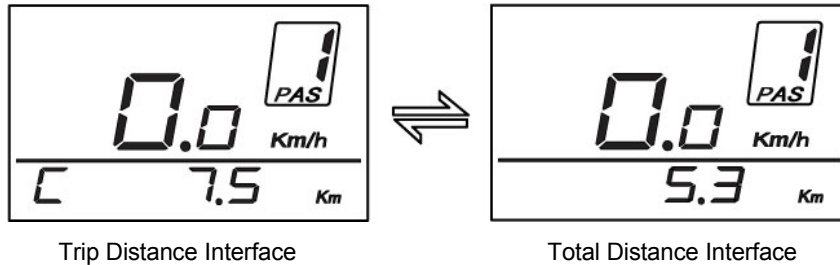

◆ Push Cruise Control

Hold **DOWN** for 2 seconds to enter the mode of power assistant walk. The e-bike will go on at a uniform speed of 6 Km/h when you hold **DOWN** always. P shows on the screen at the same time. Otherwise immediately stop 6 km/h output power when the **DOWN** is released and interface returns to the mode before the power assistant walk.



Push Cruise control

■ “Push Cruise Control” function can only be used to push the e-bike by hands.

Please don't use this function when riding.

◆ Turn on/off Backlight

Hold **UP** for 2 seconds to turn on the backlight of the display, the headlight will be power on at the same time. Hold **UP** for 2 seconds again, backlight turned off.

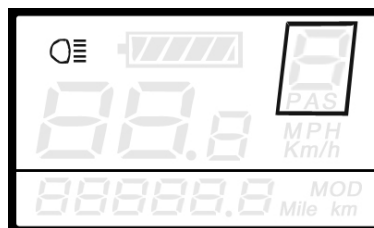

Turn On/Off Backlight

◆ PAS Level Selection

Press **UP/DOWN** to change the output power of the motor. The default power ranges

from level 0 to level 5. The output power is 0 on Level 0. Level 1 is the minimum power. Level 5 is the maximum power. Gear to level 5 and then press **UP**, the interface displays 5 still and 5 flashing prompting top; Gear to level 0 and then press **DOWN**, the interface displays 0 still and 0 flashing prompting low. The default value is level 1.

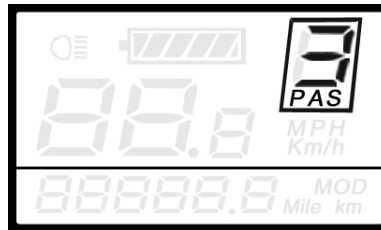

PAS Level 3

◆ **Battery Indicator**

The 6 battery bars represent the capacity of the battery. When the battery is in low voltage, battery frame will flash to notice that the battery needs to be recharged immediately.

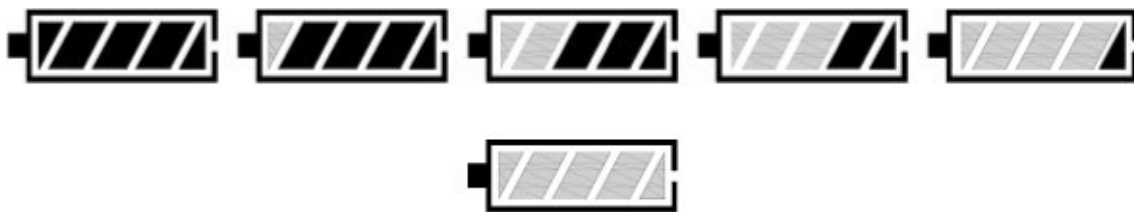

Low Voltage Flash
Battery Indicator

Error Code Information

If there are errors about the electronic control system, the error code will appear automatically. Here is the detail information of the error code in **Attached list 1**.



Error Code Indicator

■ **Make the display repaired when error code appears**

General Setting

Hold **MODE** button to start the display, then hold both **UP** and **DOWN** for 2 seconds to enter general setting menu.

■ **All the Settings are operated in the case of zero speed**

◆ Trip Distance Clearance

TC means single trip distance clearance setting, Press **Up/DOWN** to choose Y/N to clear trip distance. The default is N. Press **MODE** to confirm and enter backlight contrast setting. Various symbol definition refer to **Attached list 4**.

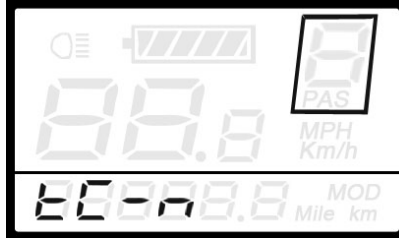

Trip Distance Clearance Setting Interface

◆ Backlight Contrast setting

BL means backlight contrast setting. Level 1 is the low brightness. Level 2 is the middle brightness. Level 3 is high brightness. The default level is 1.

Press **UP/DOWN** to modify the backlight brightness. Press **MODE** to confirm and exit the general setting.

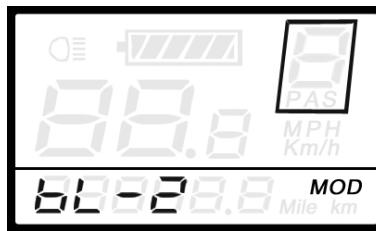

Backlight brightness Setting Interface

◆ Inch and Metric Conversion

U means unit setting, 1 is inch, 2 is metric. Press **UP/DOWN** to change the number to convert. Press **MODE** to confirm and enter backlight contrast setting. Hold **MODE** to confirm and exit general setting. U default value is 2.



Inch and Metric Conversion Settings Interface

General Parameter Setting

Hold both **UP** and **DOWN** for 2 seconds to enter User setting. Then hold both **DOWN** and **MODE** more than 2 seconds is to enter wheel diameter Setting interface.

◆Wheel Diameter Setting

Ld means wheel diameter setting. Selectable values include 16,18,20,22,24,26,700C and 28. Press **UP/DOWN** to select the correct value to match the wheel diameter. Default diameter is 20 inch. Press **MODE** to enter speed-limit setting interface.

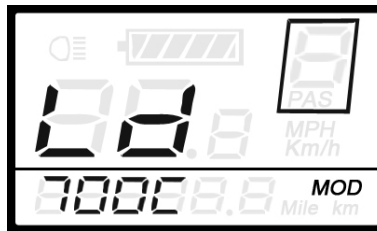

Wheel Diameter Setting Interface

◆Speed-limit Setting

LS means the limit speed setting. When the running speed is faster than limit speed, the controller will cut off the motor power. Limit speed range is 12Km/h to 40Km/h. Limit speed default setting is 25Km/h. Press **UP/DOWN** to select the favorite value, then hold **MODE** over 2 seconds to confirm and quit the setting mode.



Limit Speed Setting Interface

Personalized Parameter Setting

Personalized Parameter Setting can match variety requirements in use. There are 8 Settings items, such as Battery Power Bar Setting, Power assistant level Setting, Over-current Cut Setting , Power Assistant Sensor Setting, Speed Sensor Setting , Throttle Function Setting, System Setting and Power-on Password Setting. Please refer to the **Attached list 2**.

Hold both **UP** and **DOWN** more than 2 seconds to enter general setting, then hold both **UP** and **DOWN** again to enter personalized parameter settings items selection page.

Press **UP /DOWN** to choose the personalized parameter settings items, and press **MODE** to enter the corresponding setting page.

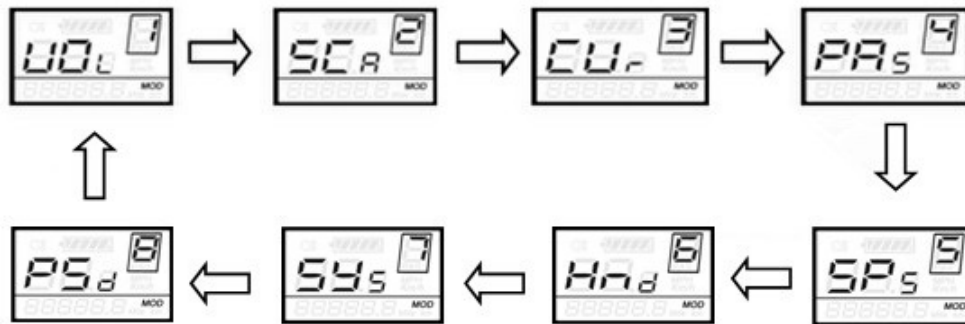

Option Select Interface

◆ **Battery Power Bar Setting**

VOL means voltage setting. Each bar represents a voltage value. 5 voltage values must be entered one by one. For example, VOL 1 is first bar voltage value, the default value is 31.5. Press **UP/DOWN** to increase or reduce the number. Press **MODE** to confirm and enter the second bar. By analogy, after 5 voltage values is entered, hold **MODE** to confirm and return to previous menu.



Battery Power Bar Setting

◆ **Power Assistant Level Setting**

Power Assistant Level Select

In power assistant level setting, there are 8 modes to select: 0-3, 1-3, 0-5, 1-5, 0-7, 1-7, 0-9, 1-9. The default mode is 0-5. Press **Up/DOWN** to select the mode, and press **MODE** to confirm and enter the PAS ratio setting page.



1-5 **flash**

PAS Mode Select Interface

PAS Ratio setting

To modify the value of PAS ratio can match the different requirements.

For example, the range is “45-55 percent” of 1 level, bottom value can be modified, and the default is 50 percent. Press **MODE** to confirm and turn to the next PAS ratio setting. After all PAS ratio inputted, hold **MODE** to confirm and return to previous menu, please refer to **Attached list 3**.



PAS Ratio Interface

◆ Controller Over-Current Cut Setting

CUR means controller over-current cut setting. CUR value can be changed from 7.0A to 22.0A. Press **Up/DOWN** to change the value of the current, and hold **MODE** to confirm the setting and return to previous menu. Default value of controller over-current cut is 15A.



CUR Setting Interface

◆ Power Assistant Sensor Setting

The Direction of Power Assistant Sensor Setting

PAS means power assistant sensor setting. “run-F” means forward direction, while “run-b” means back direction. Press **Up/DOWN** to select F or b, and press **MODE** to confirm and enter to setting mode of PAS sensitivity, the default direction is “run-F”.

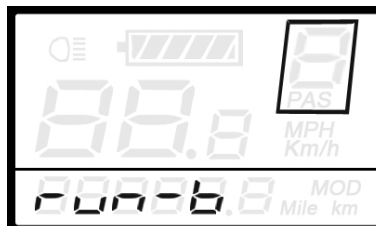

Direction of PAS Sensor Setting

The Sensitivity of PAS Setting

SCN means the sensitivity of PAS setting. The sensitivity value is 2 to 9. 2 is the strongest, 9 is the weakest. Press **Up/DOWN** to select sensitivity value, and press **MODE** to confirm selection and enter to magnet disk setting mode. The sensitivity of PAS default value is 2.



The Sensitivity of PAS Setting

Magnet quantity Setting

N means magnet numbers of PAS disk. Press **Up/DOWN** to select quantity corresponding to PAS disk. Magnet quantity default value is 6.

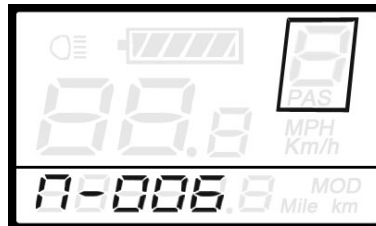

PAS Magnet Disk Setting

◆Speed Sensor Selection

SPS means speed sensor setting. Press **Up/DOWN** to select the quantity of magnet head (the range is from 1 to 9), and hold **MODE** to confirm and return to previous menu. SPS default value is 1.

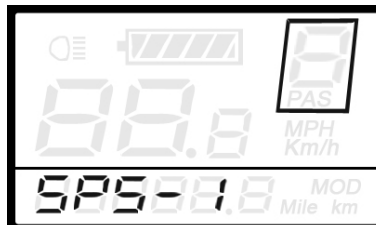

Speed Sensor Selection

◆Throttle Definition

Throttle Assistance Push Enable/Disable

HL means throttle assistance push. HL-N means throttle assistance push function is disabled. HL-Y means throttle assistance push function is enabled. Press UP/DOWN to

select Y, and press MODE to confirm the selection. Otherwise select N to enter Throttle Level Enable Setting, HL default value is N.

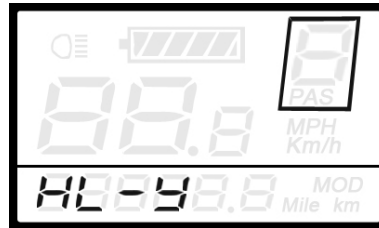

Throttle Enable/Disable Interface

Throttle Level Enable/Disable

HF-Y means throttle level is enabled, HF-N means throttle level is disabled. Press UP/DOWN to select Y or N, and press MODE to confirm and enter Throttle Enable Setting page. Hold MODE to confirm and return to previous menu. HF default value is N.

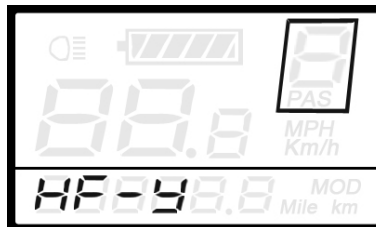

Throttle Level Enable/Disable Interface

◆System Setting

Delay time setting of battery power

DLY means delay time of battery power setting. Press **UP/DOWN** to select delay time 3, 6, 12s, then press **MODE** to confirm and enter the max speed limited. The default time is 3s.

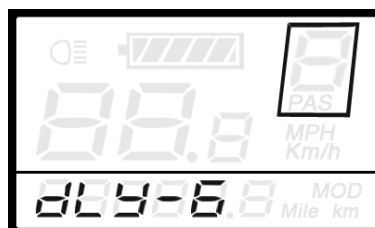

Delay time of battery power interface

Max speed limited

MAX SPD means max speed limited setting. Press **UP/DOWN** to Set the max speed from 25Km/h~40 Km/h. Press **MODE** to confirm and enter Button PAS Setting. The default is 40Km/h.

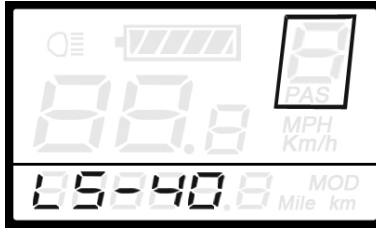

Interface of max speed limited setting

■ This setting is the priority version. The speed is the maximum set by manufacturer.

Button PAS Setting

PUS means button push setting. Press **Up/DOWN** to choose Y or N. Y means button push is enabled, N means button push is disabled. Press **MODE** to confirm and enter into PAS speed setting. The default value is Y.

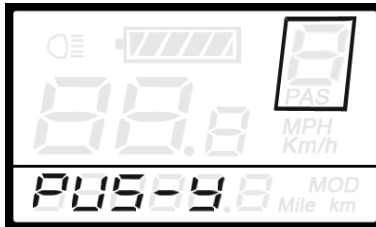

Interface of PAS push

PAS Speed Setting

Adjust push speed by setting PAS to meet rider's requirements. Press **UP/DOWN** to adjust from 20% to 35%, press **MODE** to confirm and enter into slowly start up. Default value is 25%.



Interface of PAS speed setting

Slowly Start up Setting

SSP means slowly start up. The range is 1-4, 4 is the slowest. Press **Up/DOWN** to choose, press **MODE** to confirm and turn to Delay time setting of battery power page. Hold **MODE** to confirm and return to previous menu. The default value is 1.

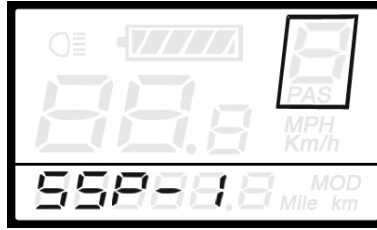

Interface of slowly setting up

◆ Power-on Password Setting

P2, 0000 on the screen means power-on password setting. Press **UP/DOWN** to change the number. Press **MODE** to confirm digit one by one. After correct 4-digit password entered, press **MODE** to confirm and enter power-on password enable setting interface, otherwise stay on the password input state. The default power-on password is 2222.



Power-on Password Entering Interface

Power-on Password Enable

Press **UP/DOWN** to select Y or N, and press **MODE** to confirm. Power-on Password default is N. If it is Y, press **MODE** to enter power-on password modify interface, otherwise exit the power-on password settings interface.

Y is Power-on Password Enable

N is Power-on Password Disable

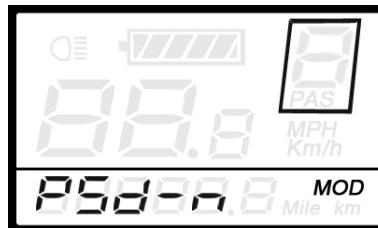

Power-on Password Disable Interface

Power-on Password Modify

When the display shows P3, 0000, press **MODE** to choose digit one by one, press **UP/DOWN** to input the new password, then hold **MODE** to confirm the modification and exit setting interface. Restarting display will show P1,0000, input the new password to power on.



Power-on Password Modify Interface

◆ Exit setting

In the setting state, pressing **MODE** (less than 2s) is to confirm the input. Holding **MODE** (more than 2s) is to save the setting, and then exit the current setting. Holding **DOWN** (more than 2s) is to cancel the operating but not saving setting data, and then return to previous menu.

■ If there is not any operations in one minute, display will exit the setting state.

Recover default setting

DEF means recover default setting. Press both **UP** and **MODE** more than 2 seconds to enter recover default setting. Press **UP/DOWN** to choose Y or N. N means that do not recover default setting. Y means that recovers default setting. When it is Y, hold **MODE** to recover default setting, the display shows DEF-00 at the same time, and then return to general display state. The default state is N.

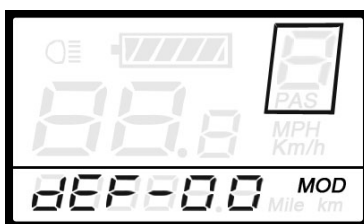

Recover Default Setting Interface

Operation Cautions

Be care of the safety use. Don't attempt to release the connector when battery is on power.

- ◆ Try to avoid hitting.
- ◆ Don't split the waterproof sticker to avoid affecting the waterproof performance.
- ◆ Don't modify system parameters to avoid parameters disorder.
- ◆ Make the display repaired when error code appears.

Quality assurance and warranty scope

I 、 Warranty

1 、 Any quality problems in normal case and during guarantee period, our company will be responsible for the warranty.

2、 The warranty time is 24 months when display out of the factory.

II 、 Other items

The following items do not belong to our warranty scope.

1、 It can not be demolished.

2、 The damage is caused by wrong installation or operation.

3、 Shell is broken when display is out of the factory.

4、 Wire is broken.

5、 Beyond Warranty period.

6、 The fault or damage is caused by the force majeure (such as fire, earthquake, etc,) or natural disasters like lighting, etc.

Connection layout

Connector line sequence

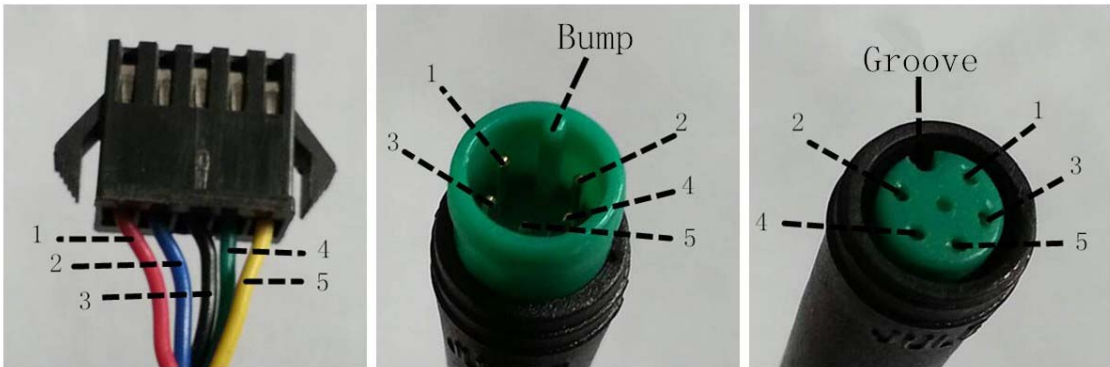

Display-side Connector

Display-side adapter

Switch wiring

Line sequence table

Line	Color	Function
1	Red (VCC)	+
2	Blue(K)	Lock
3	Black(GND)	-
4	Green(RX)	RX
5	Yellow(TX)	TX

■ Some wire use the water-proof connector, users can not see the inside color.

Attached list 1: Error code definition

Error Code	Definition
21	Current Abnormality
22	Throttle Abnormality
23	Motor Abnormality
24	Motor Hall Signal Abnormality
25	Brake Abnormality
30	Communication Abnormality

Attached list 2: Personality Parameter setting

No	Setting item	Screen display
1	Battery Power Bar Setting	UB _L
2	Power assistant level Setting	SE _A
3	Over-current Cut Setting	EU _P
4	Power Assistant Sensor Setting	PA _S
5	Speed Sensor Setting	SP _S
6	Throttle Function Setting	HA _d
7	System Setting	SY _S
8	Power-on Password Setting	PS _d

Attached list 3: Power assist table

Level Level Item	1	2	3	4	5	6	7	8	9
0-3/ 1-3	50%	74%	92%	—	—	—	—	—	—
0-5/ 1-5	50%	61%	73%	85%	96%	—	—	—	—
0-7/ 1-7	40%	50%	60%	70%	80%	90%	96%	—	—
0-9/ 1-9	25%	34%	43%	52%	61%	70%	79%	88%	96%

Attached list 4: symbol definition

No	Symbol	Definition
1	EE	trip distance clearance
2	BL	Backlight
3	U	unit
4	00E	voltage
5	ED	Wheel diameter
6	ES	Speed limit
7	EEF	controller over-current cut
8	EBEB	Backward
9	EBEF	Forward
10	SEN	sensitivity of PAS
11	SPS	speed sensor
12	DLY	Power delayed time
13	HL	Throttle power assist walk
14	HF	Throttle-changing
15	PUS	button push
16	SSP	slowly start up
17	PSD	Password
18	DEF	Recover default
19	Y	Yes
20	N	No